

S:\AFMMachines\15000 Foil Feed Systems\15800 DC Motor Mount\

ITEM NO.	DRAWING NUMBER	PartNo	DESCRIPTION	QTY.
1	15800-002	104485	15800-002	2
2	15800-001	104484	15800-001	1
3	15800-003	104483	15800-003	1
4	Foil Feed Motor			1
5	L0050 500	100055	-	1
6	L0050 375	100057	-	1
7	L0050 Spider	100058	-	1
8	15000-003	102953	Knurled roller pin (drive side)	1

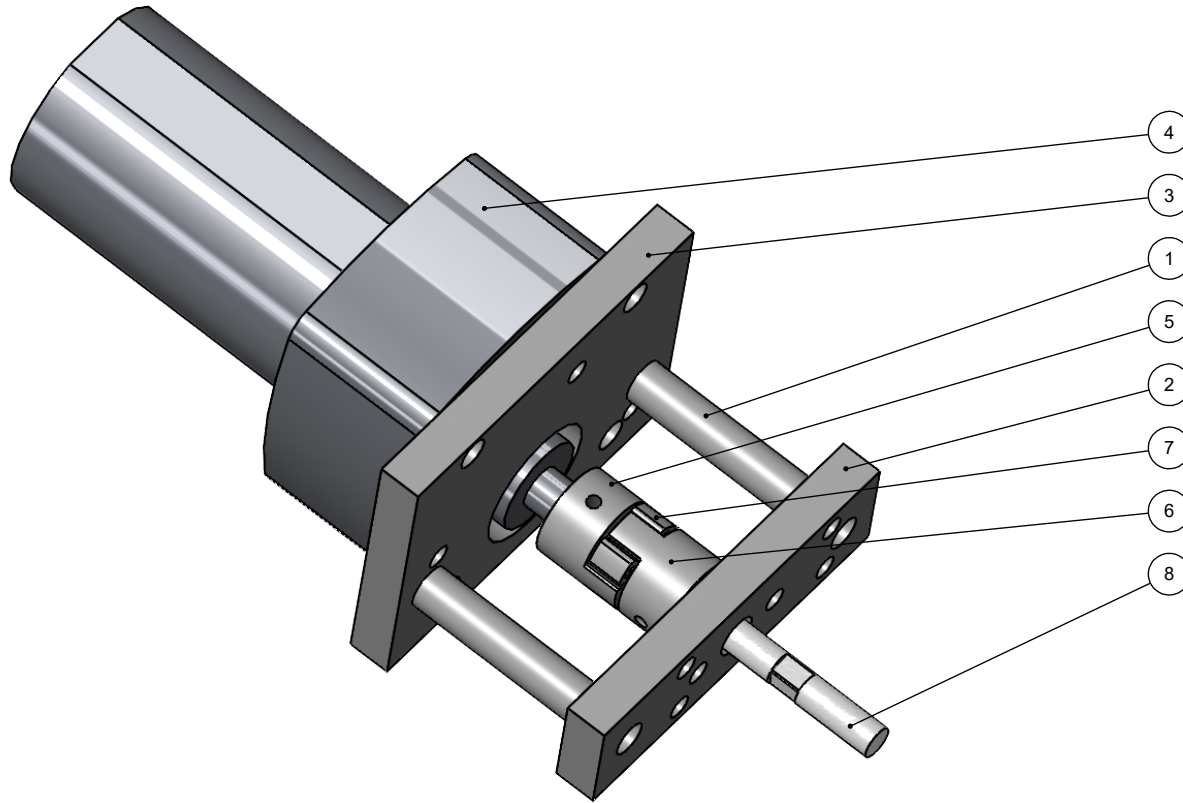

**PROPRIETARY AND CONFIDENTIAL**

THE INFORMATION CONTAINED IN THIS DRAWING IS THE SOLE PROPERTY OF AFM ENGINEERING, INC. ANY REPRODUCTION IN PART OR AS A WHOLE WITHOUT THE WRITTEN PERMISSION OF AFM ENGINEERING INC. IS PROHIBITED.

		DIMENSIONS ARE IN INCHES TOLERANCES: FRACTIONAL $\pm .032$ ANGULAR: MACH $\pm$ BEND $\pm$ TWO PLACE DECIMAL $\pm .010$ THREE PLACE DECIMAL $\pm .005$		NAME	DATE	AFM Engineering, Inc.
				DRAWN	Irwin	
				CHECKED	Irwin	2/4/2010
				ENG APPR.		
				MFG APPR.		
				Q.A.		
				COMMENTS:		AFM Engineering, Inc. Part # 101168 Foil Feed Electric Motor Mount AFM Part #101168
NEXT ASSY	USED ON	FINISH				
APPLICATION		DO NOT SCALE DRAWING				
				SIZE	DWG. NO.	REV.
				A	15800-000	
				SCALE:1:4		WEIGHT: 4.654
						SHEET 1 OF 1