

ITEM NO.	PART NUMBER	PartNo	DESCRIPTION	QTY.
1	19050-002	104717	Switch Plate	1
2	PBCircuitBreaker			1
3	2522 Nut		2522 Nut	2
4	2522	2522	Strain Relief T&B	4
5	19051-001	104720	Buttom Bar, E-stop	1
6	19050-003	104718	Blank Plate	1
7	OTBVN6	OTBVN6	Button, Optical Touch, 10-30 VDC	2
8	OTBVN6 Hood	Comes with OTBVN6	Button, Optical Touch, Hood	2
9	19050-004	104719	End Cap	2
10	19051-005	104721	Connection Plate	1

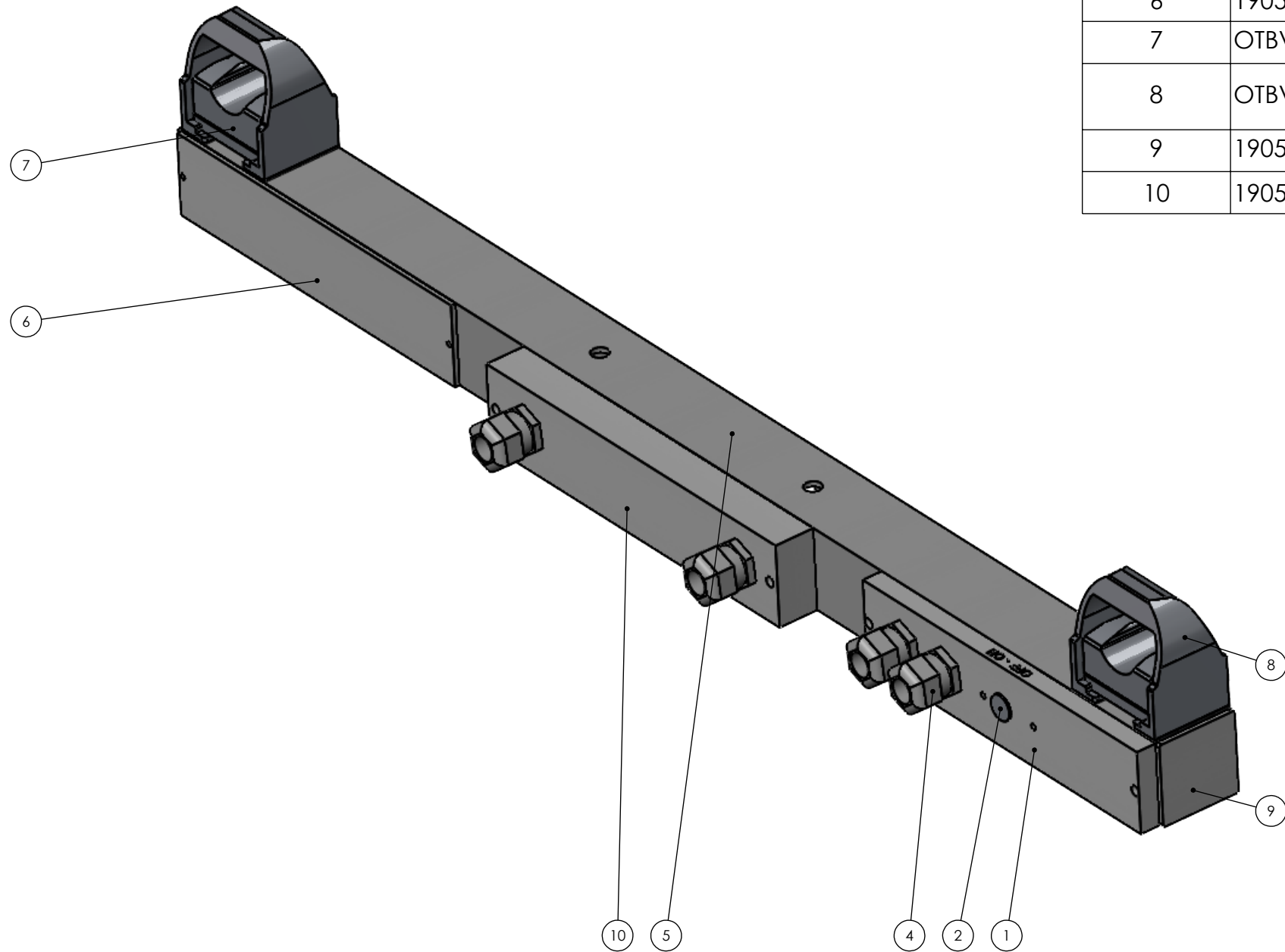

**PROPRIETARY AND CONFIDENTIAL**  
 THE INFORMATION CONTAINED IN THIS DRAWING IS THE SOLE PROPERTY OF AFM ENGINEERING, INC. ANY REPRODUCTION IN PART OR AS A WHOLE WITHOUT THE WRITTEN PERMISSION OF AFM ENGINEERING INC. IS PROHIBITED.

DIMENSIONS ARE IN INCHES		NAME	DATE	AFM Engineering, Inc.
TOLERANCES:		IRWIN	2/10/2006	
FRACTIONAL ±		IRWIN	2/10/2006	
ANGULAR: MACH ± BEND ±				
TWO PLACE DECIMAL ± .010				
THREE PLACE DECIMAL ± .005				AFM Engineering inc.
MATERIAL		MFG APPR.		Light Touch Palm Button Bar with E-Stop AFM PART # 104669
FINISH		Q.A.		
NEXT ASSY	USED ON	COMMENTS:		SIZE DWG. NO.
APPLICATION	DO NOT SCALE DRAWING			<b>B</b> 19051-000 REV.
				SCALE: 1:4 WEIGHT: 6.639 SHEET 1 OF 1