

S:\AFMMachines\19000 Hot Stamp Control Box\19200_Heater_Connection_Boxes\192030_6_Heater\

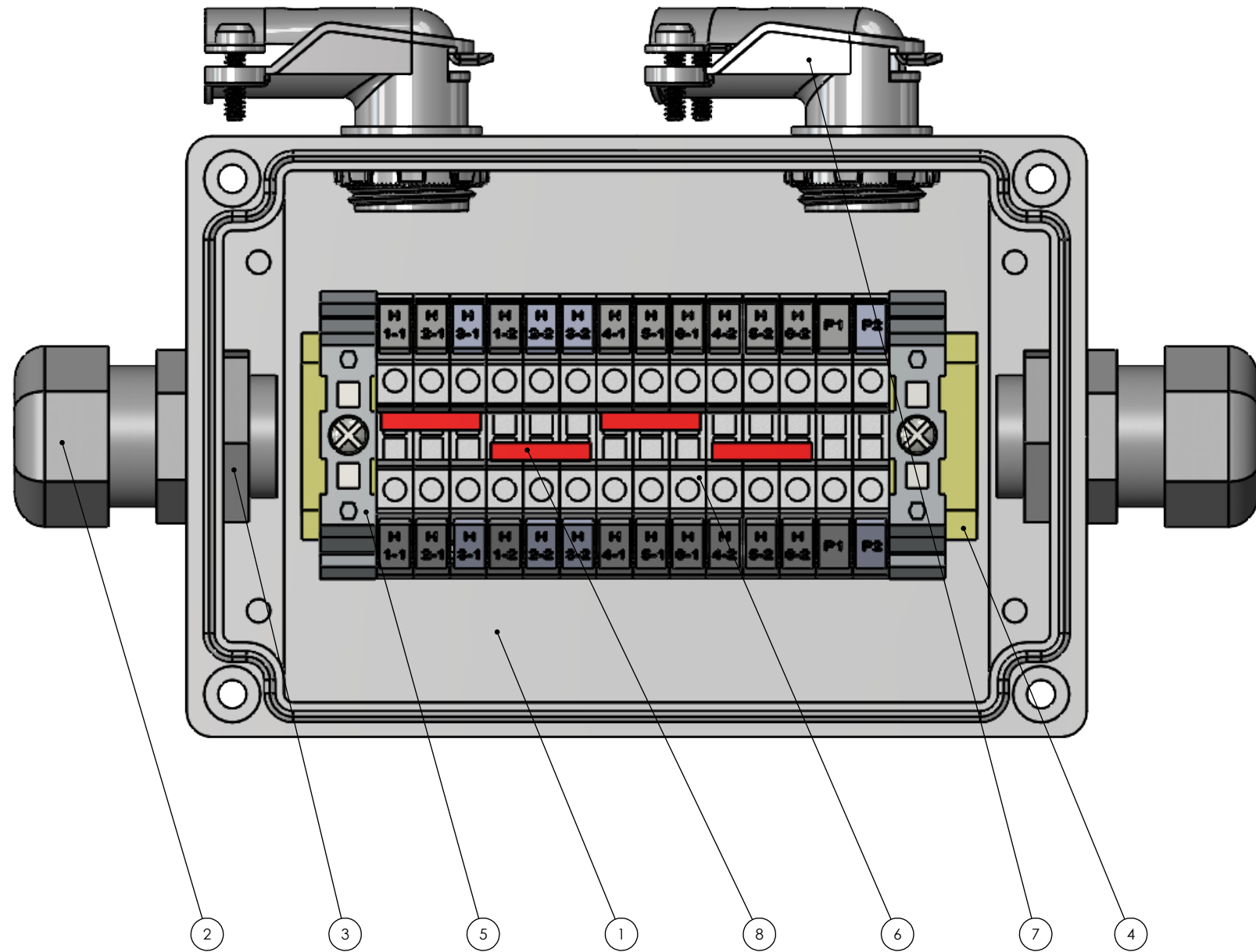

ITEM NO.	PART NUMBER	PartNo	DESCRIPTION	QTY.
1	Box_AFM	104634	Electrical Connection Box	1
2	2522	100041	Strain Relief Cord, 1/2 OD, .250 to .375	2
3	2522 Nut	100126	Locknut, 1/2", Rigid	2
4	19200-001_DinRail	105292	Din Rail for Heater Connection Box	1
5	pxc_0800886_08_05_E-NS-35-N_3D	103605	End clamp - E/NS 35 N	2
6	UT2,5 GR 3044076	103604	Feed-through terminal block UT 4 GREY	14
7	7267K33	103990	Strain Relief, 90 Degree	2
8	FBS-50-6_3D_AFM_3	-	-	4
9	UCT-TM-6_3D_P1	-	-	2

PROPRIETARY AND CONFIDENTIAL
 THE INFORMATION CONTAINED IN THIS DRAWING IS THE SOLE PROPERTY OF AFM ENGINEERING, INC. ANY REPRODUCTION IN PART OR AS A WHOLE WITHOUT THE WRITTEN PERMISSION OF AFM ENGINEERING INC. IS PROHIBITED.

		DIMENSIONS ARE IN INCHES TOLERANCES: FRACTIONAL ± ANGULAR: MACH ± BEND ± TWO PLACE DECIMAL ± .010 THREE PLACE DECIMAL ± .005		NAME	DATE	AFM Engineering, Inc. AFM Engineering, Inc. Heater Connection Boxes 6 Heaters AFM PART # 105291	
		MATERIAL		DRAWN	Irwin		-
		FINISH		CHECKED	Irwin		-
NEXT ASSY		USED ON		ENG APPR.			
APPLICATION		DO NOT SCALE DRAWING		MFG APPR.			
				Q.A.			
				COMMENTS:			
SIZE	DWG. NO.					REV.	
B	19230_6_Heaters						
SCALE: 1:2		WEIGHT: 1.343				SHEET 1 OF 1	