

S:\AFMMACHINES\37000 HEATER HEADS\37100 FRANKLIN\37140 6X12\

ITEM NO.	PART NUMBER	PartNo	DESCRIPTION	QTY.
1	37100-001	103376	DOVETAIL CLAMP STUD	1
2	37140-001	104637	6"X12"	1
3	37100-002_RevA	101113	CLAMP BOLT SIDE(SMALL)	2
4	37100-003	101110	Dovetail Clamp	1
5	37100-004_RevA	101112	CLAMP NOT BOLT SIDE	1
6	91045A033-Washer	102695 Washer	Leveling Washer	1
7	91045A033	102695 Nut	Leveling Nut	1
8	37100-005	102270	CLAMP SUPPORT	1

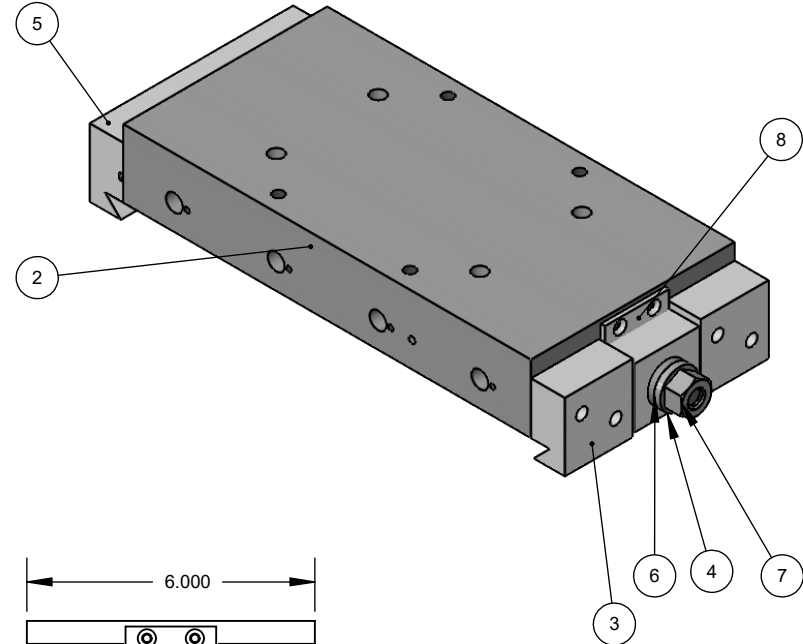
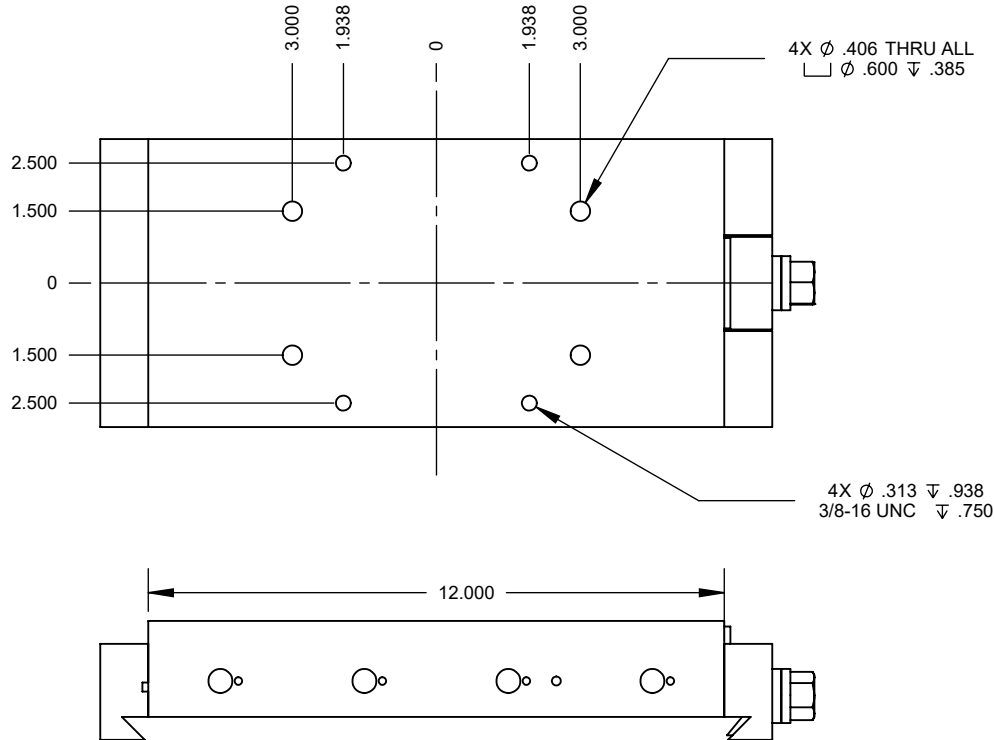

PROPRIETARY AND CONFIDENTIAL

THE INFORMATION CONTAINED IN THIS DRAWING IS THE SOLE PROPERTY OF AFM ENGINEERING, INC. ANY REPRODUCTION IN PART OR AS A WHOLE WITHOUT THE WRITTEN PERMISSION OF AFM ENGINEERING INC. IS PROHIBITED.

		DIMENSIONS ARE IN INCHES TOLERANCES: FRACTIONAL \pm .032 ANGULAR: MACH \pm BEND \pm TWO PLACE DECIMAL \pm .010 THREE PLACE DECIMAL \pm .005	NAME	DATE
DRAWN	Irwin		-	
CHECKED	Irwin		-	
ENG APPR.				
MFG APPR.				
		MATERIAL		
NEXT ASSY	USED ON	FINISH		
APPLICATION		DO NOT SCALE DRAWING		

AFM Engineering, Inc.

Franklin
Heater,
Head 6 X 12
AFM Part #103127

SIZE	DWG. NO.	REV.
A	37140-000	
SCALE:1:4	WEIGHT: 14.371	SHEET 1 OF 1