

S:\AFMMachines\15000 Foil Feed Systems\15100 Stripper Bar\Franklin\10X15

ITEM NO.	PART NUMBER	DESCRIPTION	QTY.
1	15100-002 10inch Vertical	STRIPPER BAR VERTICAL 10 INCH	2
2	15100-003 2inch Spacer	-	4
3	15100-008 13inch Horizontal	-	1
4	HNUT 0.3750-16-D-N		4
5	Preferred Narrow FW 0.375		4
6	SPS 0.125x0.625		5
7	Default		2

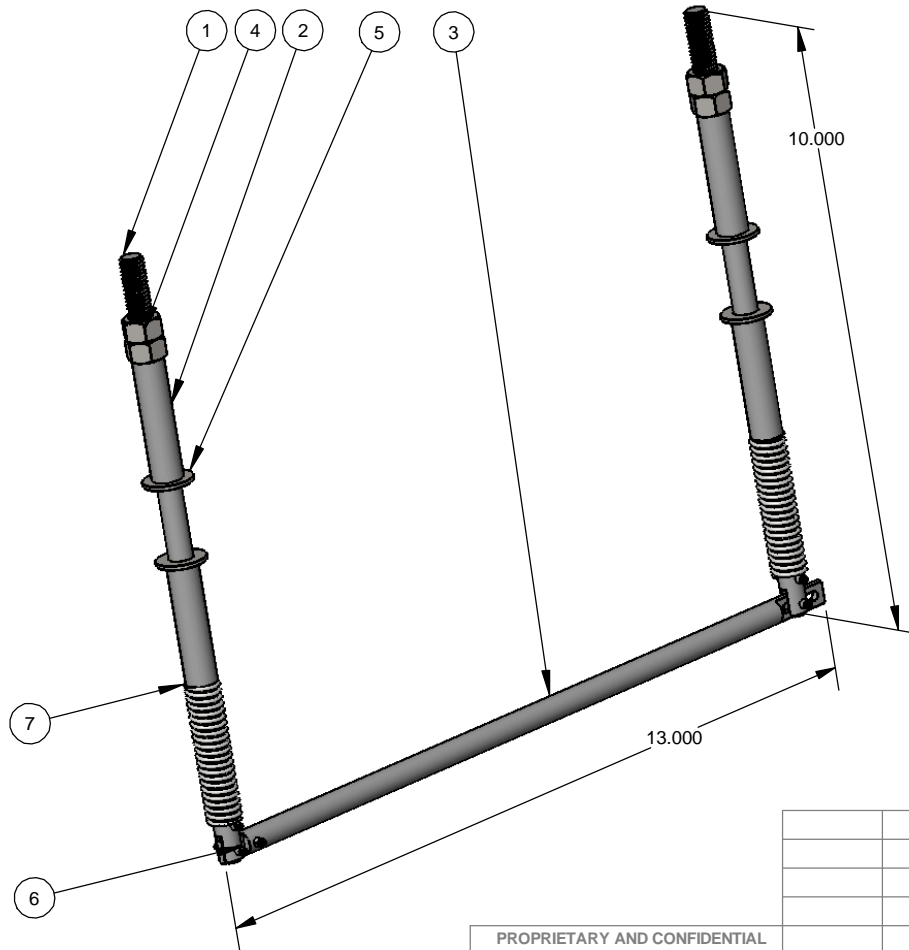

PROPRIETARY AND CONFIDENTIAL

THE INFORMATION CONTAINED IN THIS DRAWING IS THE SOLE PROPERTY OF AFM ENGINEERING, INC. ANY REPRODUCTION IN PART OR AS A WHOLE WITHOUT THE WRITTEN PERMISSION OF AFM ENGINEERING INC. IS PROHIBITED.

		DIMENSIONS ARE IN INCHES TOLERANCES: FRACTIONAL ±.032 ANGULAR: MACH ± BEND ± TWO PLACE DECIMAL ±.005 THREE PLACE DECIMAL ±.010		NAME	DATE	AFM Engineering, Inc.	
				Irwin	-		
				Irwin	-	FRANKLIN KENSOL-FRANKLIN - STRIPPER BAR ASSEM 10X15, 10L Part # 103584	
				COMMENTS:		SIZE DWG. NO. REV.	
NEXT ASSY	USED ON	FINISH				A 15932-000 10X15 10 Vertical	
APPLICATION		DO NOT SCALE DRAWING				SCALE:1:1 WEIGHT: 0.402 SHEET 1 OF 1	