

S:\AFMMachines\86000\_Disc\_Fixtures\86100\_Die\_Mounting\86110\_7InchX7Inch\_Die\_Holder\

ITEM NO.	PART NUMBER	DESCRIPTION	QTY.
1	002_7X7_Die_Holder_With_Holes	7X8 Hot Plate Chase Drilled Template	1
2	002_7X7_Die_Holder_Dovetail59130	7"X7" Die Mounting Dovetail	1

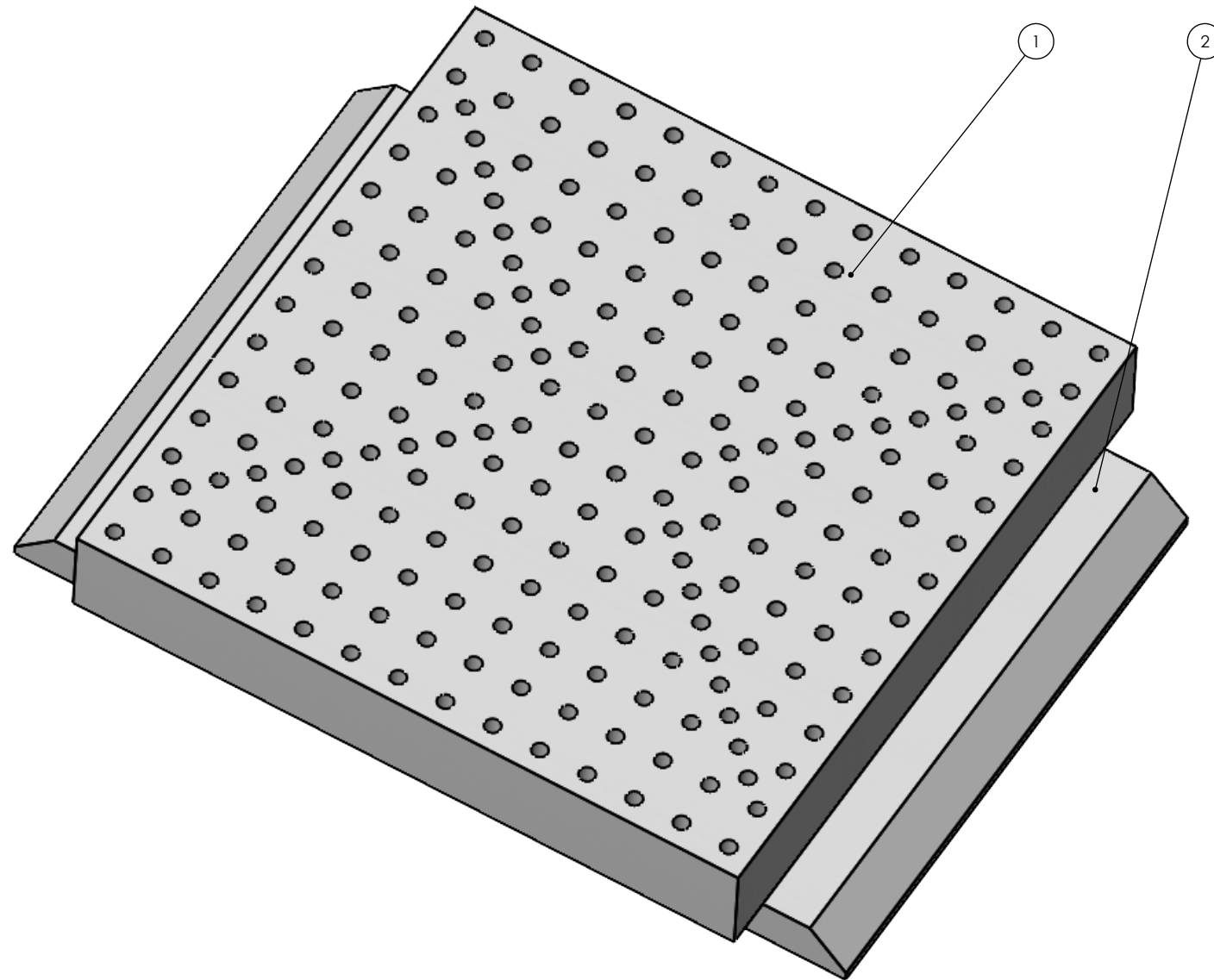

**PROPRIETARY AND CONFIDENTIAL**  
 THE INFORMATION CONTAINED IN THIS DRAWING IS THE SOLE PROPERTY OF AFM ENGINEERING, INC. ANY REPRODUCTION IN PART OR AS A WHOLE WITHOUT THE WRITTEN PERMISSION OF AFM ENGINEERING INC. IS PROHIBITED.

		DIMENSIONS ARE IN INCHES		NAME		DATE		AFM Engineering, Inc.	
		TOLERANCES:		DRAWN		7/30/2023		AFM Engineering, Inc. Gold Disc Die Holders 7"X7" Die Block Drilled AFM PART # 105180	
		FRACTIONAL ±		CHECKED		7/30/2023			
		ANGULAR: MACH ± BEND ±		ENG APPR.					
		TWO PLACE DECIMAL ± .010		MFG APPR.					
		THREE PLACE DECIMAL ± .005		Q.A.					
		MATERIAL		COMMENTS:					
NEXT ASSY	USED ON	FINISH							
APPLICATION		DO NOT SCALE DRAWING							
SIZE	DWG. NO.							REV.	
B	861100-000_7InchX7Inch_Die_Holder_With_Holes								
SCALE: 1:2		WEIGHT: 6.914		SHEET 1 OF 1					