

ITEM NO.	PART NUMBER	Partno	DESCRIPTION	QTY.
1	003_86160_6Dia_Die_Holder_With_Holes	103615	6X8 Dovetail Drilled Template	1
2	001_86160_6Dia_Die_Holder_With_Holes	103119	Dovetail 6 X 8	1

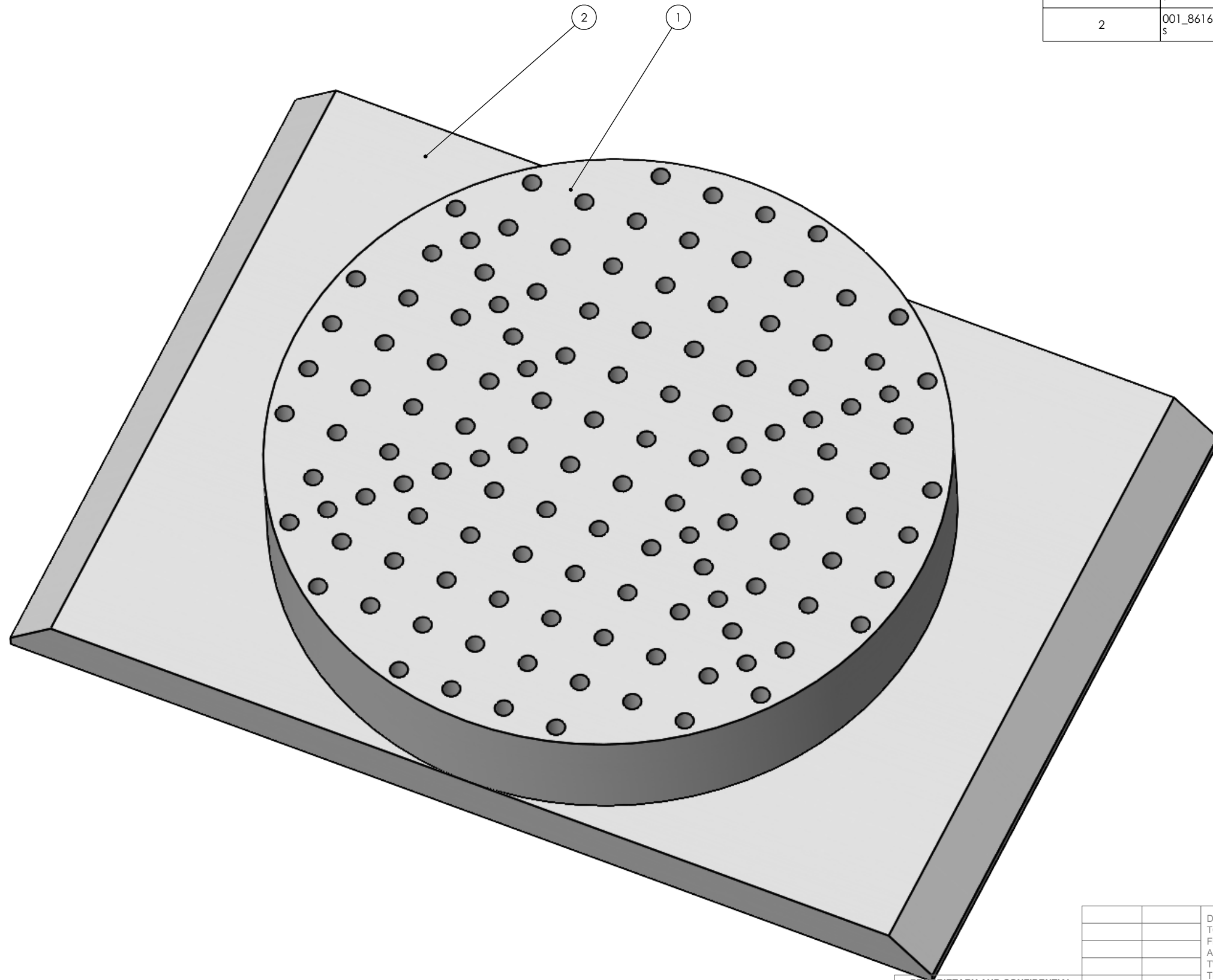

PROPRIETARY AND CONFIDENTIAL  
 THE INFORMATION CONTAINED IN THIS DRAWING IS THE SOLE PROPERTY OF AFM ENGINEERING, INC. ANY REPRODUCTION IN PART OR AS A WHOLE WITHOUT THE WRITTEN PERMISSION OF AFM ENGINEERING INC. IS PROHIBITED.

DIMENSIONS ARE IN INCHES		NAME	DATE	AFM Engineering, Inc.	
TOLERANCES:		DRAWN	Irwin	7/30/2023	AFM Engineering, Inc. Golf Disc Printing Die Blocks 6" Dia Die Block Drilled 6"X8" Dovetail AFM PART # 105188
FRACTIONAL ±		CHECKED	Irwin	7/30/2023	
ANGULAR: MACH ± BEND ±		ENG APPR.			
TWO PLACE DECIMAL ± .010		MFG APPR.			
THREE PLACE DECIMAL ± .005		Q.A.			
MATERIAL		COMMENTS:		SIZE	DWG. NO.
NEXT ASSY	USED ON	FINISH		B	000_86160-6Dia_Die_Holder_with_Holes
APPLICATION		DO NOT SCALE DRAWING		SCALE: 1:2	WEIGHT: 4.972
				SHEET 1 OF 1	