

S:\AFMMachines\59000 Dovetails\59900_United_Silicone\59900_8X8_Dovetail\

ITEM NO.	PART NUMBER	PartNo	DESCRIPTION	QTY.
1	003_59900_8X8_Dovetail	105376	8 inch X 8 inch Dovetail Plate	1
2	001_59900_8X8_Dovetail	105378	8 inch X 8 inch Dovetail Clamp	2
3	002_59900_8X8_Dovetail	105377	Dovetail Stop Bracket	2
4	ASME B18.8.2 - 0.1877x1			4
5	HFBOLT 0.3125-18x1.25x0.875-N			2
6	Preferred Narrow FW 0.3125			2
7	HX-SHCS 0.19-32x0.875x0.875-N			2
8	HJNUT 0.2500-20-D-N			2
9	94105A547	94105A547	Alloy Steel Flat-Tip Set Screws	2

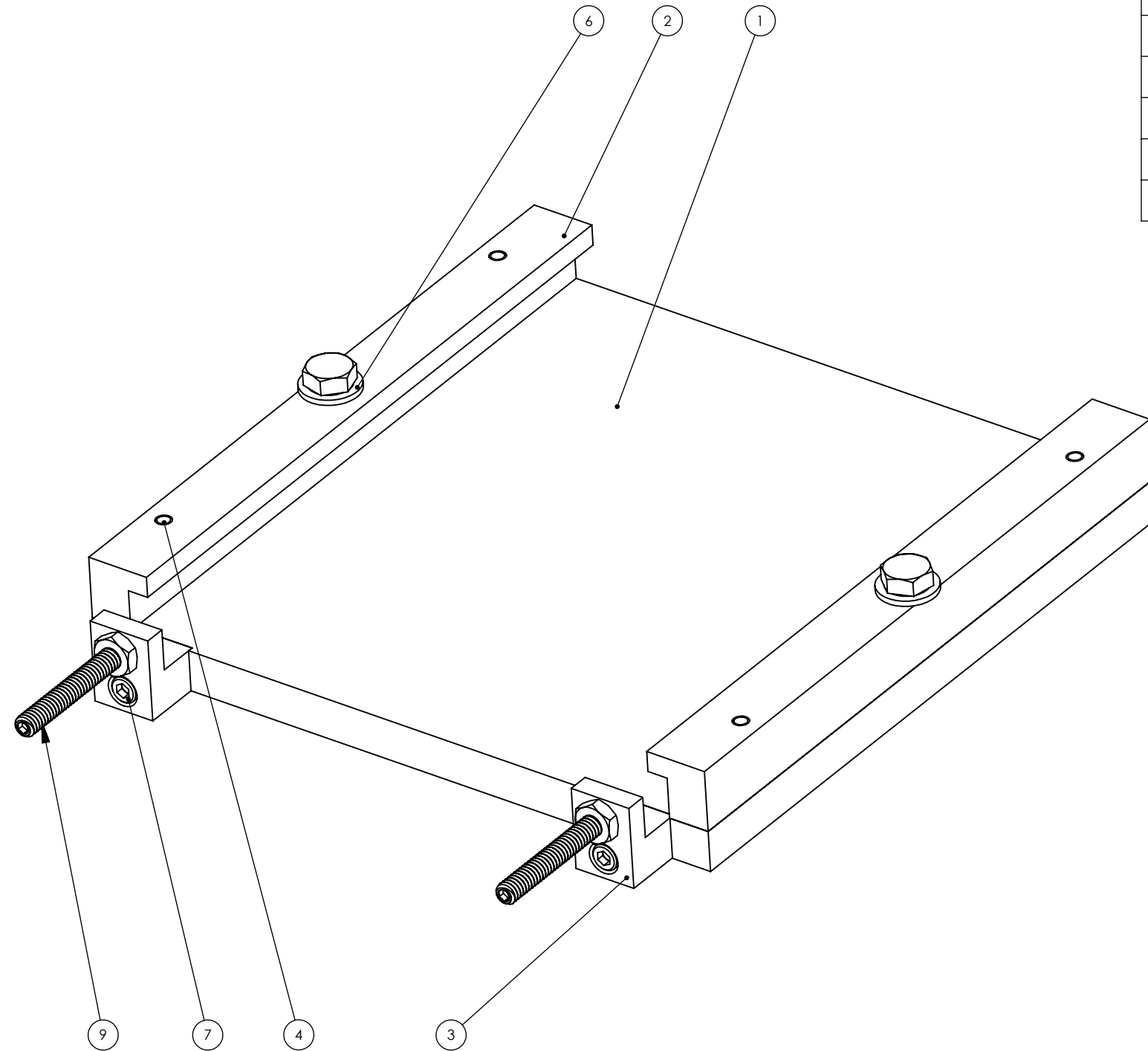

PROPRIETARY AND CONFIDENTIAL
 THE INFORMATION CONTAINED IN THIS DRAWING IS THE SOLE PROPERTY OF AFM ENGINEERING, INC. ANY REPRODUCTION IN PART OR AS A WHOLE WITHOUT THE WRITTEN PERMISSION OF AFM ENGINEERING INC. IS PROHIBITED.

		DIMENSIONS ARE IN INCHES		NAME		DATE	
		TOLERANCES:		DRAWN		-	
		FRACTIONAL ±		Irwin			
		ANGULAR: MACH ± BEND ±		CHECKED		-	
		TWO PLACE DECIMAL ± .010		Irwin			
		THREE PLACE DECIMAL ± .005		ENG APPR.			
		MATERIAL		MFG APPR.			
NEXT ASSY		USED ON		Q.A.			
APPLICATION		DO NOT SCALE DRAWING		COMMENTS:			
				AFM Engineering, Inc.			
				United Silicone Dovetail, United Silicone 8 inch X 8 inch AFM PART # 105375			
SIZE		DWG. NO.		REV.			
B		59900_8X8_Dovetail_000					
SCALE: 1:2		WEIGHT: 3.443		SHEET 1 OF 1			